

# MASTER CLOCK AND TIME DISTRIBUTION SYSTEM FOR THE NASA DEEP SPACE NETWORK

**J. Lauf, M. Calhoun, P. F. Kuhnle, R. L. Sydnor, and R. L. Tjoelker**  
**Jet Propulsion Laboratory**  
**California Institute of Technology**  
**Pasadena, CA 91109, USA**

## Abstract

*NASA's Deep Space Network (DSN) consists of more than 20 antennas located at three globally spaced ground communications facilities (Goldstone, CA USA; Madrid, Spain; Canberra, Australia). Local generation and distribution of precise time and frequency reference signals comprise an essential and central component of each complex. Within each complex, synchronized timing references are required by approximately 100 users located at distances up to 30 kilometers from the central control center and station Master Clock. In this paper, a highly modular, hot-swappable, and expandable system design for generation, delivery, and synchronization of highly precise and stable timing signals over fiber-optic cables is described.*

## INTRODUCTION

The generation, calibration, and synchronization of timing signals are central to space navigation and tracking activities in the NASA Deep Space Network (DSN). The DSN is a unique capability with extraordinary sensitivity for tracking spacecraft within and beyond the solar system and detecting very weak natural radio emissions from the far reaches of the universe. The network consists of numerous ground-based antennas and associated high-performance systems, including a highly precise and stable Frequency and Timing Subsystem (FTS) to provide frequency and timing reference signals.

Currently, the DSN operates three major Deep Space Communications Complexes (DSCCs) located near Goldstone, California; Canberra, Australia; and Madrid, Spain. The local antenna sites are located in remote valleys away from heavily populated areas so that weak radio signals are not obscured by radio interference from sources such as power lines, radio and TV stations, and household and industrial appliances. The longitudinal separation between each complex is approximately 120 degrees, with two north of the equator and one south, making it possible for any spacecraft in the ecliptic plane to establish line-of-site communication with at least one ground station at any time. Each complex consists of several large parabolic reflector antennas (diameters of 70, 34, and 26 meters) and associated low-noise and ultra-sensitive receiving systems. Oversubscribed ground-based resources to track multiple flight missions (currently 17) place a very high demand on availability and reliability of each DSCC subsystem.

The Frequency and Timing Subsystem (FTS) is a key component to the successful operation and high performance of each complex. The DSN and the FTS have slowly evolved over the years, growing in both capability and complexity. The present timing system was developed in the late 1970's, and while historically reliable, has limited capacity and has become increasingly difficult to operate and sustain. In

this paper, a system level description for a new Master Clock and Time Distribution System appropriate for the DSN or other similar demanding operational environments is described.

## DSN FREQUENCY AND TIMING SUBSYSTEM

The DSN requires both state-of-the-art frequency and timing performance as well as very high reliability. Each DSCC operates an independent FTS (Figure 1) to generate and distribute reference signals to as many as 100 users. These coherent signals are centrally generated and distributed to users at distances of up to 30 km, as schematically shown for the DSCC at Goldstone, California, USA in Figure 2. The central source of stable frequency and timing for the entire DSCC originates from a single atomic frequency standard, often referred to as the “online” standard. Backup standards of varying performance are available. Sinusoidal frequency reference signals, most commonly at 5, 10, and 100 MHz, are distributed over a variety of copper coax and fiber-optic cables to end users in both the central control area and to antenna sites at greater distances. Significant attention is given to selecting distribution cable properties to minimize thermally induced phase delays. Active feedback is introduced to stabilize the most demanding frequency distribution applications, typically for radio science [1].

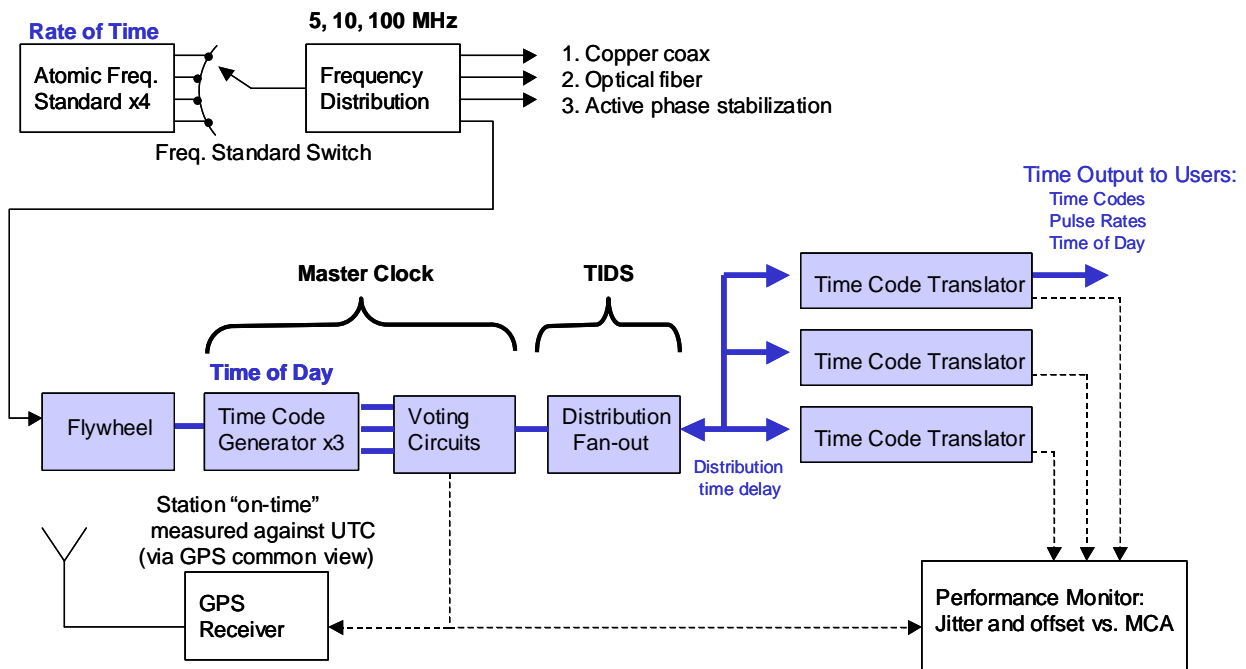

Figure 1. Schematic representation of the present DSN Frequency and Timing Subsystem with the shaded boxes representing major components of the timing chain. For clarity, monitor and control for the three time code generators, the voting circuitry, and the distribution fan-out (TIDS) are not shown.

The timing system consists of a central Master Clock that derives its rate from the online frequency standard. Time of day and pulse rate reference signals must be distributed with time offsets between each user and the DSCC master clock known. The synchronization of the master clock at each DSCC relative to Universal Coordinated Time (UTC) is accomplished via Common View GPS time transfer. The

knowledge of time offsets with respect to UTC and ultimately to the earth-based timescale UT1 is critical for tracking activities of the DSN and successful spacecraft navigation [2].

## EXISTING TIMING SYSTEM

The existing timing system was developed during a DSN era with fewer antennas and with fewer missions to support. The early DSN focused on planetary flyby missions culminating in the Pioneer (Jupiter 1974, Saturn 1979) and Voyager (Jupiter 1979, Saturn 1981, Uranus 1986, and Neptune 1989) missions to the outer planets. These missions had stringent navigation and radio science requirements with multiple activities that had to occur during brief planetary encounters lasting only a few hours. These DSN activities had a timing requirement that a separate test time be distributed to “simulate” and rehearse future operations scenarios. This feature, referred to as “Simulation Time,” and the needed monitor and control resulted in a very complicated timing distribution system. Since this era, each DSCC has grown considerably more complex, with multiple antennas and many more missions in flight to track. Furthermore, each complex today has a centralized UNIX-based monitor and control network to operate a mix of complex assets. This system is not time-translation friendly. This much busier and complicated network interface environment contributed to the obsolescence of the Simulation Time requirement in the operational DSN.

The existing DSN timing system, shown in the shaded boxes in Figure 1, encompasses five electronics racks to contain a triply redundant Master Clock and Time Insertion Distribution Assembly (TIDS). The TIDS provides the time distribution to the user interface, called Time Code Translators (TCT), which are located throughout the DSCC. The three Time Code Generators (TCG) outputs are majority-voted to eliminate a TCG in the event of a failure. The voted clock output is then passed to the TIDS assembly, where a unique 100 kHz pulse width modulated code (TIDS code) is generated. This code is similar in structure to IRIG-G with the addition of information to carry Simulation Time, the TCT address, and flag bits to warn users of an upcoming Leap Second or Leap Year event. The timing rate at each TCT is derived via a 5 MHz reference, also from the TIDS. A multi-conductor cable between the TIDS and each TCT is used to return detailed TCT status monitor data. This detailed monitor information is handled by an integrated TIDS monitor and control system also used to carry out TIDS control functions, such as selecting which subset of TCTs to operate with Simulation Time. A similar monitor and control exists for the master clock and both systems communicate with the central complex monitor and control system via a historically troublesome IEEE-488 interface bus. The highly integrated monitor and control system is built around assemblies fabricated with 1970’s wire-wrap technology and Z80 processors. An additional cable for offset calibration and monitoring returns a 1 pps signal back to the central control room from those TCT’s that are within approximately 1 km of the TIDS. The need for four separate cables between the TIDS and the approximately 100 TCT users creates a large cable management challenge for the DSCC’s.

Over the years, several TCT models have been developed to accommodate different time codes and pulse rates required by various users. Distribution delays can be removed to a resolution of 100 ns using delay compensation switches. Typical TCT jitter stability is at the 2 ns rms level, with some of the more recent versions capable of 700 ps rms. The initiation of leap seconds, leap year, or the setup of Simulation Time is performed via the monitor and control system, which historically could also be controlled through each DSCC local area network. The leap second or year activities also required that manual switches at the Master Clock be set, defeating any benefit of centralized control.

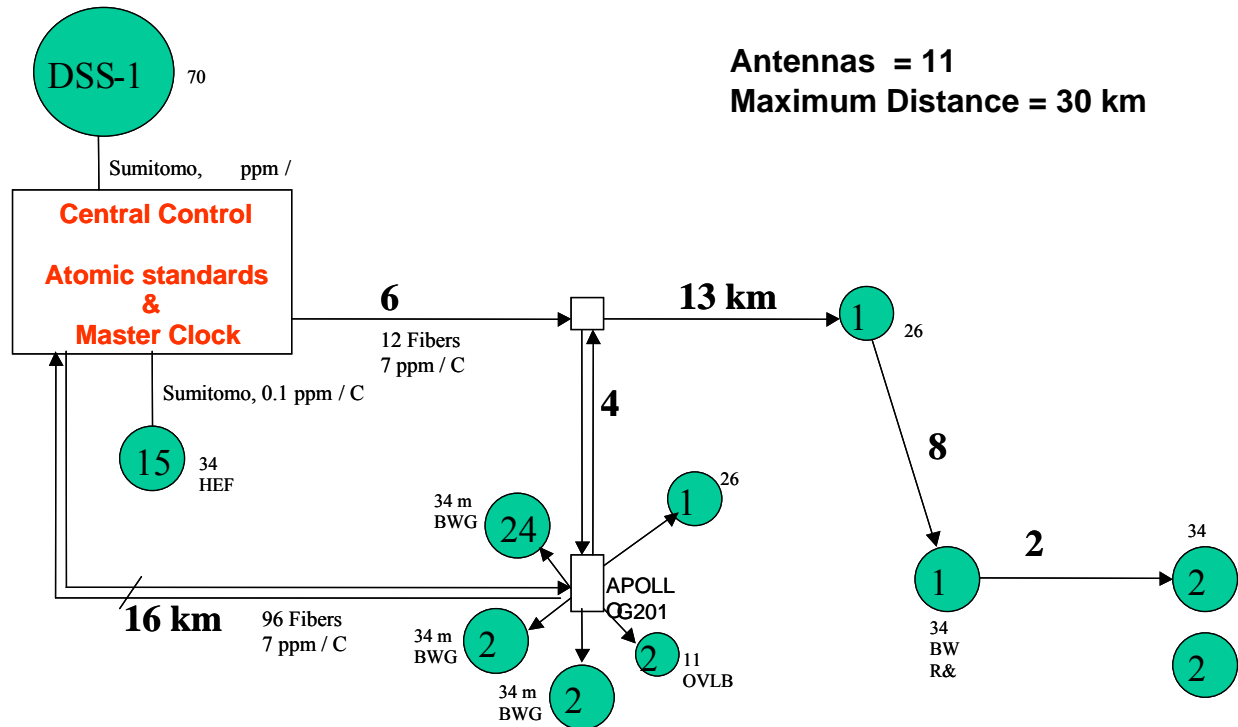

Figure 2. Schematic view of the antenna layout at the NASA Deep Space Complex at Goldstone, California USA, showing fiber-optic connections and distribution distances up to 30 km.

Given the complexity of the existing system, the reliability has been very good, though because of age increased anomalies have recently occurred. The stability performance has been sufficient for most DSN activities though hardware, and firmware have been difficult to sustain for several years. Given its critical nature and relatively few failures, station operators have little opportunity to gain experience in troubleshooting and repair.

## NEW TIMING SYSTEM DESIGN

### DESIGN CONSIDERATIONS AND GOALS

The central design philosophy for the new system is that it be viewed foremost as a precision reference system with focus on very high reliability and operability. Performance improvements were incorporated where feasible and did not compromise reliability. The replacement system must be easier to operate by personnel with little or no expertise in the timing system. The detailed requirements for the new design are captured in a Technical Requirements Document [3]. In summary, key considerations and goals driving the design are:

- Design as a precision reference with operability considerations. Eliminate TCT-addressability.
- Eliminate central/network control. Automate leap year function and manually set leap second.
- Simplify status data to only high-level information for easy interpretation and action.
- Simplify setup interface and add coarse time recovery to an IRIG B signal from a GPS receiver.

- Use fiber-optic cables for distribution and reduce multiple existing DSN cables.
- Integrate 1 pps loop-back monitor fiber to verify offset and jitter at each TCT.
- Use hot-swap modular approach with common chassis and power supplies.
- Design distribution to be modular and expandable to accommodate future growth.
- Maintain existing TCT form factor and use plug-in module approach to meet varying output needs.
- Develop with the involvement of a commercial timing company for module nonrecurring engineering and production.
- Design to expected 20-30 years operational life and appropriately document and archive the design to meet long-term DSN sustaining needs.
- Integrate MCA flywheel capability and add TCT holdover capability.
- Improve MCA settability to 10 ns increments.
- Improve TCT synchronization settability to  $\pm 5$ ns.
- Improve pulse-to-pulse jitter to  $< 200$  ps.
- Automate leap year and provide year in distribution code.
- Output Codes: RS-232 Serial, NASA36, IRIG-B, PB-1, BCD parallel.
- Output Time Pulse Rates: 1, 10, 100, 1k, 10k, 100k, 1M PPS.

### SYSTEM DESIGN OVERVIEW – MAJOR ASSEMBLIES

The new timing system design is comprised of three major hardware assemblies, interconnected via a fiber-optic infrastructure and shown in Figure 3. Timing signals originate in the **Master Clock Assembly (MCA)**. The MCA is set to UTC and generates a System Time Code (STC) for distributing time of day and timing rate information to the entire DSCC. This distribution is accomplished by passing the

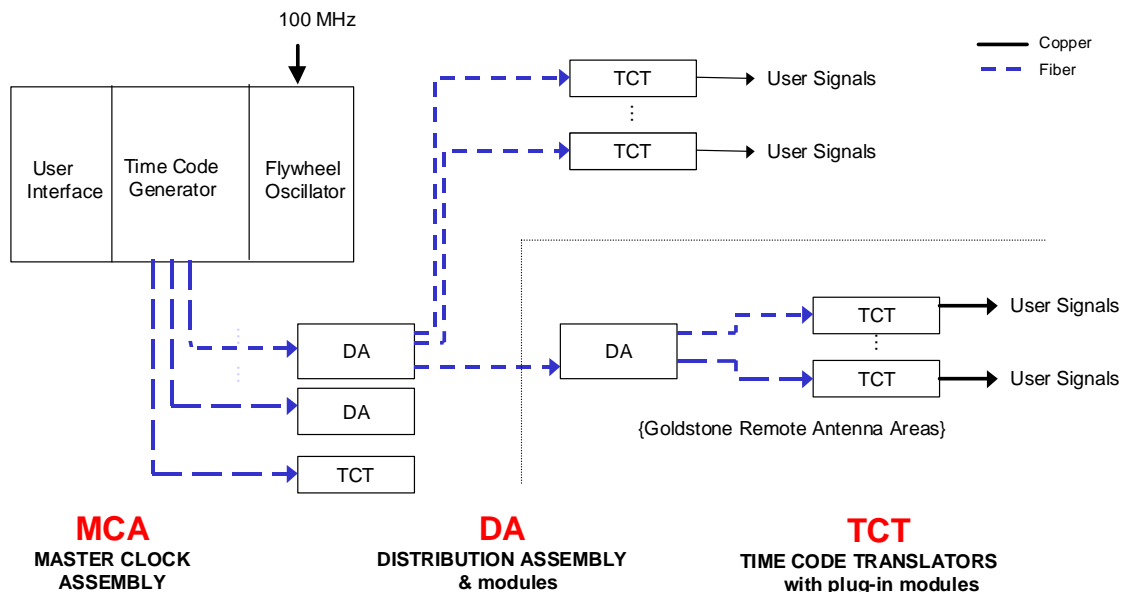

STC

over fiber-optic cable to a **Distribution Assembly (DA)**. The DA is filled with 10 Distribution Modules (DM), each of which reconstitute the STC and transmit the signal either to a second DA for additional fan-out or to a **Time Code Translator (TCT)**, which provides the end-user timing reference interface. The TCT compensates for transmission delays from the Master Clock and can generate a variety of time codes and pulse rates as required.

A more detailed view of the modules in each major assembly is shown in Figure 4. Both the MCA and the DA reside in identical chassis with dual, hot-swap power supplies. The TCT is a standardized mainframe in a 1U chassis preserving the same form factor of the existing timing system in the DSN. The back of the TCT can accommodate four plug-in modules to provide different time code and pulse rate outputs.

The **Master Clock Assembly** contains five modules, four of them unique: a front-panel user interface that incorporates a few simple operator setup and slew functions, a 100 MHz flywheel, a single Time Code Generator, and dual redundant power supplies. The user interface allows an operator to “jam-set” the Time Code Generator either manually or using an externally generated IRIG-B signal. The rate of time accumulation is then dependent on the DSCC 100 MHz reference frequency, typically derived from a hydrogen maser. The station time, as defined by the Master Clock, can be manually slewed in any combination of decade step sizes from 10 ns to 100 ms. The Master Clock has knowledge of the current

Figure 3. Major assemblies and fiber-optic distribution fan-out hierarchy of the new timing system design.

year and implements leap-year rollover automatically. Provision is made to manually set leap seconds (add or subtract) for any day of the year. During normal operation, the stability of the generated timing rates traces directly to the DSCC atomic frequency standard. For uninterrupted operation in the event of

Figure 4. New timing system showing detailed module configuration.

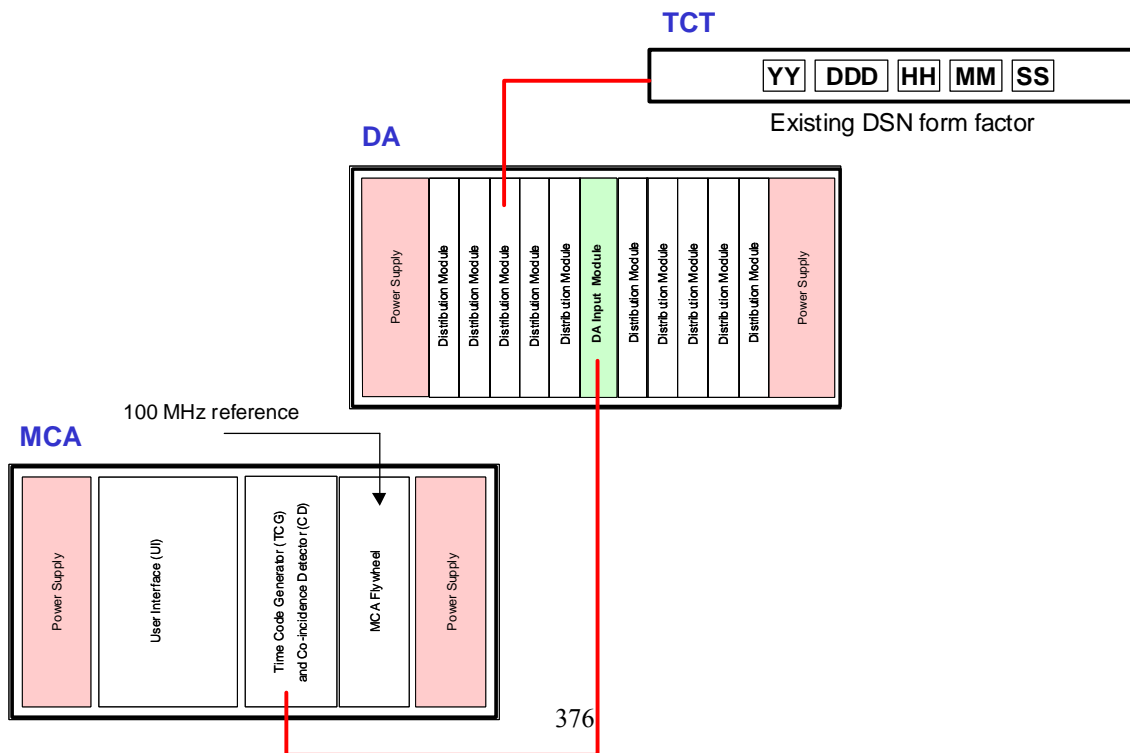

loss of the 100 MHz reference frequency, the Master Clock Assembly incorporates a TCXO phase-lock loop flywheel designed with a holdover function to drift less than 3 ms over 24 hours.

The **Distribution Assembly** contains 13 modules, three of them unique. The input module receives the optical System Time Code generated in the MCA Time Code Generator and fans the signal out to up to 10 output modules. The signal from any of the 10 output modules can then be transmitted either to a second stage Distribution Assembly or directly to a TCT. The optical time code signal transmitted by the Distribution Assembly is identical to the signal generated by the TCG. This means that there can be an unlimited number of fan-out stages between the TCG and the end-user TCT and there is no limit to the number of users that can be connected to the Master Clock.

The final stage in the distribution chain is the **Time Code Translator**. The TCT receives the optical System Time Code and uses the embedded 100 MHz carrier to phase-lock a TCXO identical to that in the MCA flywheel. 100 MHz provides a resolution that can accommodate time distribution delay settability at the 10 ns level. Delay compensation is accomplished by setting hidden dip switches inside the TCT mainframe chassis. These switches are ordinarily adjusted only during initial installation and calibration. The System Time Code and rate are derived from the optical signal and sent to one of four identical, rear plug-in module slots within the TCT. Any of the four slots can then be populated with a module configured to produce either pulse rates ranging from 1 pps to 1 Mpps in decade increments, or a range of common time codes such as IRIG-B, NASA36, BCD, PB-1, etc. The distribution System Time Code and the 100 MHz output of the TXCO are made available at the plug-in connectors in order that future timing needs can be accommodated, simply by designing a new plug-in module with the appropriate output.

## DUAL FLYWHEEL APPROACH

The new system design incorporates a “dual-flywheel” implementation. The first flywheel resides in front of the MCA Time Code Generator. A second is built into every TCT that resides at the timing reference user interface. This provides significant operational robustness over the present timing system and secondary benefits as well.

The MCA flywheel resides in the MCA chassis, and benefits from the dual redundant power supplies and module hot swappability. The main purpose of the flywheel is to hold MCA time in the event of loss of signal or change of the online atomic frequency standard. While the timing performance will slowly degrade, the complex will remain operational until the reference signal can be restored.

In the new system design, a second flywheel is in each individual TCT. With a TCT flywheel, time code outputs and pulse rates continue to be generated in the event of timing signal interruption anywhere in the distribution infrastructure. This holdover is allowed for up to 12 hours, more than sufficient time to diagnose and repair the distribution-related anomaly and to keep basic operation of the complex going through an antenna track.

The TCT holdover flywheel also opens up the possibility of delivering stable frequency references via the timing distribution system. Since the TCXO is phase-locked to the embedded 100 MHz optical System Time Code, it becomes possible, with appropriate VCO loop bandwidth, to deliver the long-term frequency stability of the online standard at TCT user outputs. The DSN currently has a separate capability for distribution of very-low phase noise, high-stability frequency reference signals (see, e.g., [1]). These support the highest-performance users, especially VLBI and Radio Science, but many users do not require such levels of performance. Significant simplification to the DSN equipment and cable

infrastructure could result if such users derived moderate performance reference frequencies from this timing system. This approach is currently under study at JPL.

### SYNCHRONIZED HOT BACKUP

The new MCA design incorporates only a single TCG. This is a major departure from the present system with three separate TCG's and associated voting circuitry. This decision was driven by analysis indicating that the voting circuitry and flywheel were more likely to fail than the single TCG configuration. By incorporating the flywheel into the MCA chassis with dual hot-swap power supplies, some of the vulnerability of a stand-alone flywheel has been reduced.

Since the entire MCA can be constructed in a single 4U chassis, our approach for redundancy in event of MCA failure is to operate with a synchronized hot backup (Figure 5). A second MCA assembly will reside near the online MCA and be synchronized at setup using the same 100 MHz input frequency. The TCG output of each MCA is compared in coincidence to monitor for possible failure. In the event of this rare occurrence, distinguishing which TCG failed should be straightforward. If the online MCA fails, multiple failure alarms will be present in the Distribution Assemblies following the MCA. To recover, an operator simply must move the TCG output fiber to the adjacent backup clock. Furthermore, since all TCT's have their own flywheel, the only visibility to timing users of a change of master clock will be a slight degradation in stability performance and no discontinuity in operation.

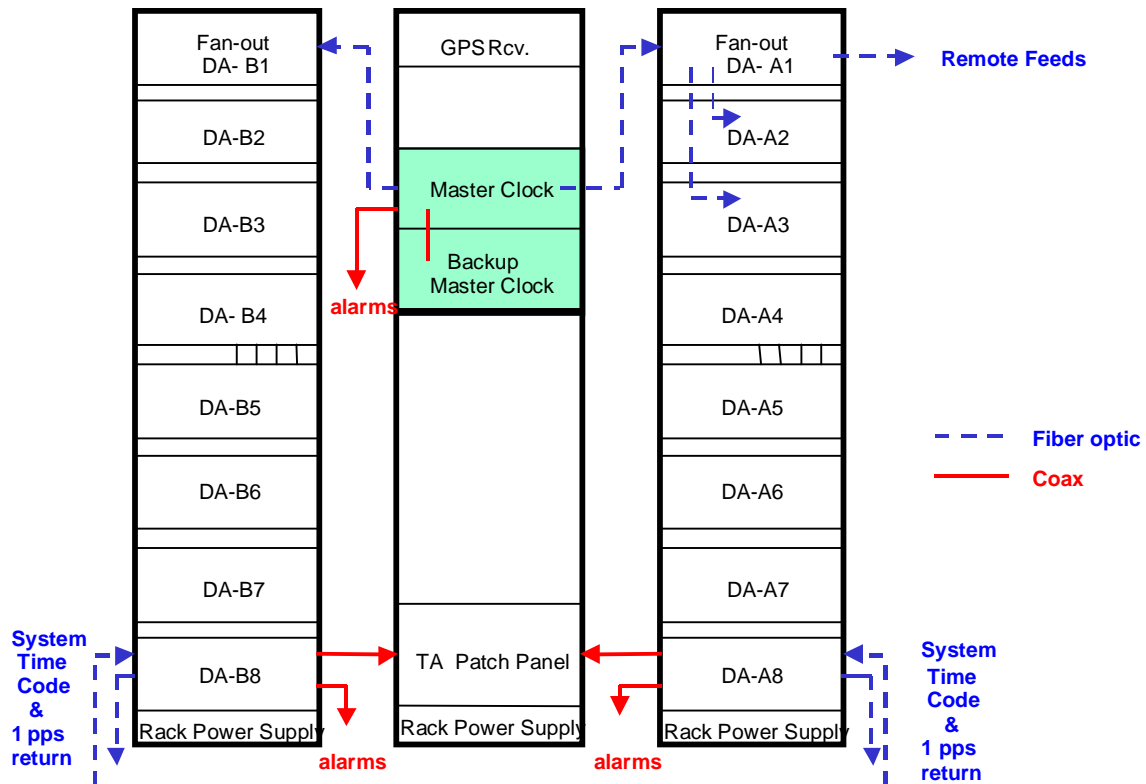

Figure 5. Schematic rack layout and MCA and synchronized hot-backup configuration.



## **DSN FIBER-OPTIC DISTRIBUTION APPROACH**

The DSN timing system is highly integrated into the existing DSN infrastructure. Transitioning from a copper cable infrastructure to a fiber-optic infrastructure during continuous station operation will be a large undertaking. The new design allows for significant cable infrastructure simplification with the replacement of four copper cables per TCT with a single fiber-optic cable.

The majority of timing distribution is at distances less than 2 km and will be accomplished using multimode fiber-optic cables. Each cable will contain four fibers. One transmits the System Time Code. One serves as the 1 pps monitor loop-back return. This loop-back return signal is collected at the Distribution Module (DM) and fed to an existing Time Analysis System [4] for verification of offset and jitter with respect to the MCA. The other two fibers will serve as spares.

For fiber-optic cable distribution to antennas less than 2 km from the MCA, a single 12-fiber cable will be installed to a breakout box in each antenna. This cable, in principle, could support up to six TCT's. Presently each antenna typically has two TCT's to support antenna pointing and uplink/downlink activities. For longer distances between 2-30 km, single-mode fiber-optic cables are used and are currently in place. Presently, timing signals from the TIDS are transmitted over these lines using a variety of commercial hardware. With the new system, this existing hardware will all be replaced with a Distribution Module that accommodates a Single Mode fiber-optic transmitter and receiver.

In all cases, efforts have been made to keep the system modular while minimizing the number of connectors required. The trunk cables to each antenna will be cut to length. As it is possible that this system may be used for some future frequency reference distribution, attention will be paid to minimizing connector count.

## **MONITOR AND CONTROL APPROACH**

In the busy operational DSN environment, the approach to monitor and control is an important consideration. The DSN Frequency and Timing subsystem has little need for real-time configuration changes (in contrast to, e.g., antenna pointing, which requires new configuration for every spacecraft track). In the FTS, the only configuration control actions are selection of frequency standard, and the setup of leap seconds. The new timing system carries year information in the System Time Code and leap-year rollover is automated. The addition or subtraction of leap seconds is a relatively rare event currently occurring on average less than once a year.

In the DSN operational environment, operators already have an overabundance of status and fault information to analyze. For the new Master Clock, the only information provided to operations is that which facilitates isolation of a failure to the module level. Local alarm indications at the TCT, visible as lighted front panel LED's, are summed together and communicated back up to the DA simply by blanking the 1 pps monitor return signal. A missing pulse detector (MPD) circuit in each DA module alarms an LED visible at the transmitter module. Each DA chassis has one alarm representing the summed alarms of all 10 modules. This alarm is passed further up the chain or collected by a Status Summary monitor computer visible to the DSN operators' monitor and control console. With modularity, and simple go – no go monitor and alarm information, oversubscribed personnel can maintain FTS operations with little understanding of the nuances of the precision timing system.

By design, there is no central or remote control of the Master Clock and Distribution System. After initial configuration through the front panel interface and calibration of distribution delay to each TCT, interaction with the MCA and distribution system is minimal. By keeping the design simple, eliminating software and detailed monitor and control, and incorporating the dual redundant flywheel scheme, few failures that could negatively impact DSN operations are anticipated over the estimated 20-30 year operational life.

## SUMMARY

A new timing system with features and capabilities sufficient to meet the demanding operational needs of the NASA Deep Space Network has been described. Modular nonrecurrent engineering and hardware production are being performed with support from private industry. To date, an Engineering Model has been produced and the design, functionality, and performance evaluated. Production, integration, testing, and implementation into the DSN are planned for the second half of calendar year 2004.

## ACKNOWLEDGMENTS

This work was carried out by the Jet Propulsion Laboratory, California Institute of Technology, under contract with the National Aeronautics and Space Administration.

## REFERENCES

- [1] M. Calhoun, R. Wang, A. Kirk, W. Diener, G.J. Dick, and R.L. Tjoelker, 2001, “*Stabilized Reference Frequency Distribution for Radio Science with the Cassini Spacecraft and the Deep Space Network*,” in Proceedings of the 32<sup>nd</sup> Annual Precise Time and Time Interval (PTTI) Systems and Applications Meeting, 28-30 November 2000, Reston, Virginia, USA (U.S. Naval Observatory, Washington, D.C.), pp. 331-340.
- [2] C. Thorton and J. Border, 2000, “*Radiometric Tracking Techniques for Deep Space Navigation*,” JPL Publications 00-11, Monograph 1 Deep Space Communications & Navigation Series.
- [3] “*Frequency and Timing System Master Clock and Timing Group Replacement*,” JPL Technical Requirements Document, DSMS No. TRD-517892, JPL D-22188, March 1, 2002 and Rev. A, 8 April 2003.
- [4] J. Gonzalez, Jr., M. Calhoun, S. Cole, and R. L. Tjoelker, 2001, “*Multi-purpose Time Analyzer and Monitor for Deep Space Network Time Synchronization*,” in Proceedings of the 32<sup>nd</sup> Annual Precise Time and Time Interval (PTTI) Systems and Applications Meeting, 28-30 November 2000, Reston, Virginia, USA (U.S. Naval Observatory, Washington, D.C.), pp. 341-354.

## QUESTIONS AND ANSWERS

**TOM CLARK (Syntonic):** Fiber optics are very interesting to many of us as ways to handle time and frequency distribution. Can you comment on the stability within the station facility? And how repeatable are connectors, cables, and so forth?

**JOHN LAUF:** Well, we have paid a lot of attention to the fiber-optic signal, and in fact we incorporated various design changes which minimized the number of connectors in the distribution system. We had originally designed in various patch panels. After looking at the system more closely, we chose to eliminate those as far as possible.

From the tests that we have undertaken so far, the performance that is delivered to the users – that slide is not up there at the moment – but it is actually well within the specifications provided originally. The jitter that we are seeing after a 2-kilometer run is on the order of around about 30 picoseconds at the users.

**DEMETRIOS MATSAKIS (U.S. Naval Observatory):** At the USNO, we have a much simpler system. But our ultimate calibration of it is to carry a cesium back and forth between our buildings. Do you do that kind of a thing? What is the ultimate calibration?

**LAUF:** I guess that was skipped over somewhat in the presentation, but from each of the users, there is the returned optical 1-PPS. That is fed back to the central controller. At the stations, we have an existing time analyzer which I did not discuss here. That monitors the performance of every TCT continually. The performance of each TCT is logged. So we can monitor the performance indirectly of every user in the station. This is without going into the details of the time analyzer hardware itself.

**MATSAKIS:** So if there was a systematic effect at one site, you would see it?

**LAUF:** Okay, you are talking at the site as opposed to individual users. In one of the earlier slides, we showed that the output of the master clock is continually monitored by the time analyzer and, of course, tracked against GPS, as well using a TTR-5.

The performance of the online standards is actually a wide suite of various monitoring control systems from, particularly, the online frequency standards. We monitor phase and frequency of all four standards. The 1-PPS signal is essentially the monitor of the performance, both of the master clock and the users.

**DENNIS McCARTHY (U.S. Naval Observatory):** Some years ago, we saw a timing requirement, or a projected timing requirement, for JPL for space navigation of sub-nanosecond. I see what you are showing here is a 20- to 30-year lifetime that does not exactly go sub-nanosecond. Has that been changed?

**LAUF:** It depends on what aspect of the performance you are talking about. The setability of the users in relation to the central master clock is 10 nanoseconds. There is no predicted user who will want setability greater than that. The jitter, of course, is well under that, so currently we are delivering, as I said, around the order of 30 picoseconds.

